

PROTECTOR WITH SCALE

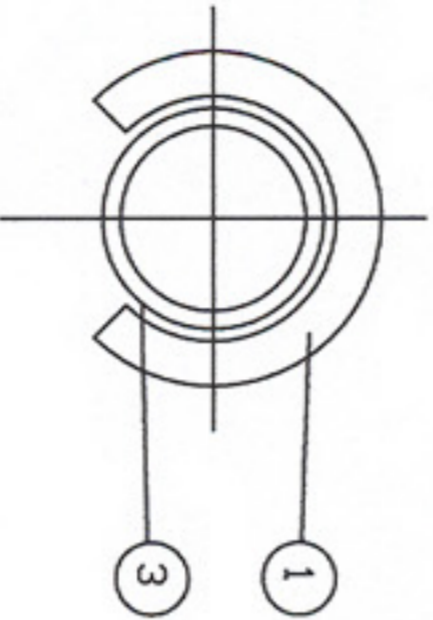

PROTECTOR WITH TUBE

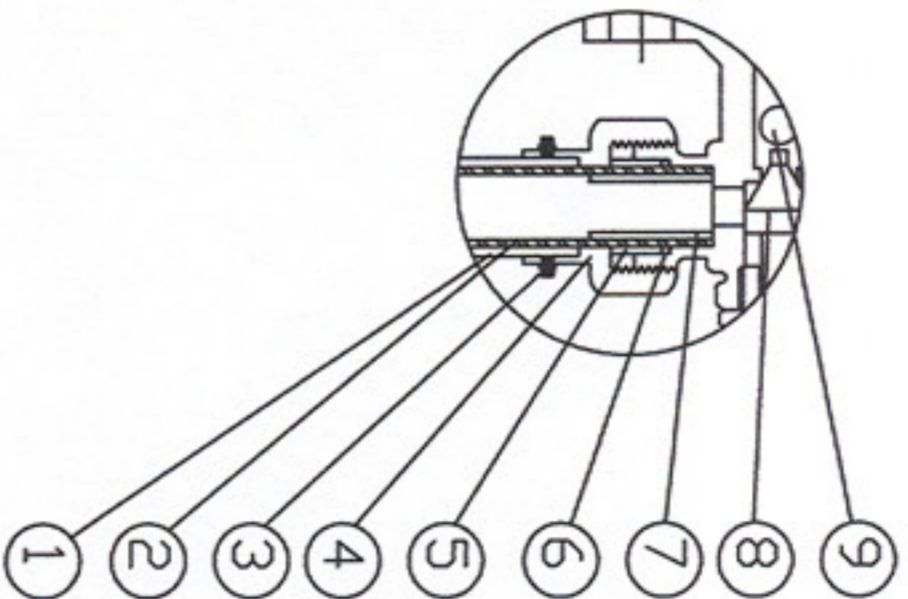
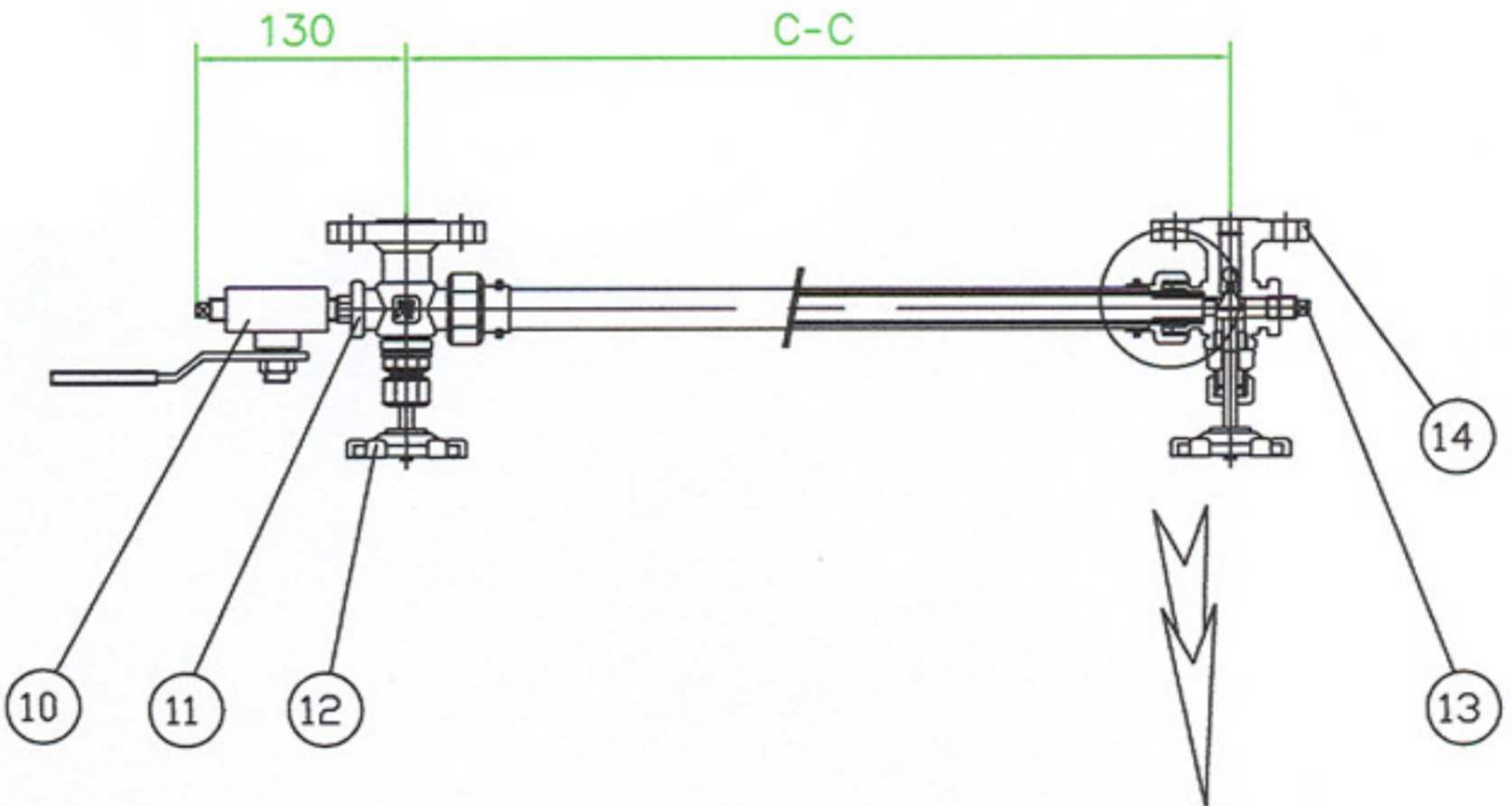

DIMENSION OF FLANGE

UNIT : mm

NO.	SIZE	FLANGE RATING	φD	φC	φG	T	F	N-φH
1	1/2"	ANSI 150# RF	89	60.3	35.1	11.5	1.6	4-16
2	3/4"	ANSI 150# RF	98	69.0	42.9	13.0	1.6	4-16
3	1"	ANSI 150# RF	108	79.4	50.8	14.5	1.6	4-16
4	1 1/2"	ANSI 300# RF	95	66.7	35.1	14.5	1.6	4-16
5	3/4"	ANSI 300# RF	117	82.5	42.9	16.0	1.6	4-19
6	1"	ANSI 300# RF	124	89.9	50.8	17.5	1.6	4-19
7								

NO.	DESCRIPTION	MATERIAL	Q'TY	REMARKS
15	CON'N FLANGE	304SS	2	
14	VENT PLUG	304SS	2	1/2" PT
13	VALVE HANDLE	FCD	2	
12	GAUGE COCKS	304SS	2	
11	DRAIN VALVE	304SS	1	1/2" PT(BALL)
10	CHECK BALL	316SS	2	
09	VALVE SPINDLE	304SS	2	
08	INNER TUBE	304SS	2	
07	SEALING O-RING	VITON	2	
06	GLAND	304SS	2	
05	JOINT UNION	Brc	2	
04	FIX BOLT & NUT	304SS	6	MS
03	TUBE	PFA	Nm	Di.18 TEFLON
02	PROTECTOR	ALUMINIUM	Nm	
01	DESCRIPTION	MATERIAL	Q'TY	REMARKS

DESIGNED By	APPROVED By	SAVE No	SCALE
B.W. KANG	H.S. LEE	TB-F	N/A
REV. No	UNIT	DATE : JUNE.30.2005	TITLE
0	mm		LEVEL GAUGE
WOOL Enterprises, Ltd			KBS, TUBULAR TYPE TOP & BOTTOM
DWG.No			KBS-TB-304